



International Refrigeration Conference at
Purdue,
Purdue University, West Lafayette, USA,
06.2000

Perspectives of Aluminum as a Construction Material for Stationary Air-Conditioning Systems

SOLVAY FLUOR UND DERIVATE GmbH

Technical Service - Refrigerants –

Product Bulletin no. C/06.00/14/E

PERSPECTIVES OF ALUMINUM AS A CONSTRUCTION MATERIAL FOR STATIONARY REFRIGERATION AND AIR-CONDITIONING SYSTEMS

F. Flohr, C. Meurer, Dr. H.-W. Swidersky, Dr. H.-J. Belt
Solvay Fluor und Derivate GmbH, Hannover, Germany

Abstract

Today Aluminium is more and more recognized as an attractive construction material for the refrigeration and air conditioning industry. The choice of joining techniques for Aluminium parts in refrigeration systems is receiving significant interest. Following up investigations of the influence of the Aluminium brazing processes on systems operating on R134a and PAG lubricant in a previous publication for this conference, analogous investigations were performed on a system operating on R407C and POE lubricant. In the automotive industry the production of Aluminium brazed heat exchangers is already successfully established. Micro channel heat exchanger designs are discussed for stationary systems as well. In addition to the discussions about the system chemistry this paper will outline possible benefits of brazed heat exchangers when compared to mechanically expanded types.

Introduction

Since brazed Aluminium heat exchangers were successfully introduced in automotive air-conditioning systems, the interest of using them in stationary refrigeration and air-conditioning has grown. Compared to automotive applications where R134a / PAG lubricant is mostly used, mixtures of refrigerants and POE lubricants are used in stationary applications, especially for the substitution of R22.

Investigations with R407C, a blend containing R32/R125/R134a and a POE lubricant, were performed to provide information on possible interactions between brazed flux residues and the refrigerant lubricant mixture within the refrigeration system. With these results it will also be possible to comment on its components R125 and R32, which have not been examined before and consequently also on R410A, a second promising R22 substitute which contains R125 and R32.

The refrigerant/oil mixture, which circulates through a refrigeration unit, is complex. The used POE oil shows hygroscopic behaviour. The flux residues remain on the surface of the brazed parts as a thin adherent non-corrosive layer. It cannot be excluded that these residues have contact to the circulating refrigerant oil mixture. This paper discusses possible interactions between the refrigerant-oil mixture and the flux residues.

The test results relate to a procedure that was established to investigate interactions among R134a/PAG lubricants and Nocolok® Flux residues [1].

Commonly used heat exchangers for stationary air-conditioning applications are manufactured by mechanically expanding the tubes in order to achieve a firm contact with the fin collars. A metallurgical bond as achieved by brazing may reduce the heat transfer resistance when compared to the mechanical bond. To estimate the heat transfer benefit, a literature research about different theoretical calculation methods for the evaluation of thermal contact resistance between tube and fin-collar is included in this work. Comparative performance tests with mechanically expanded and brazed heat exchangers are planned for the future.

Test program R407C / POE oil and Nocolok® Flux residues

The test program that is described in figure 1 was carried out to obtain knowledge on interactions of Nocolok® Flux residues in refrigeration and air conditioning systems operating with R 407C and POE lubricant.

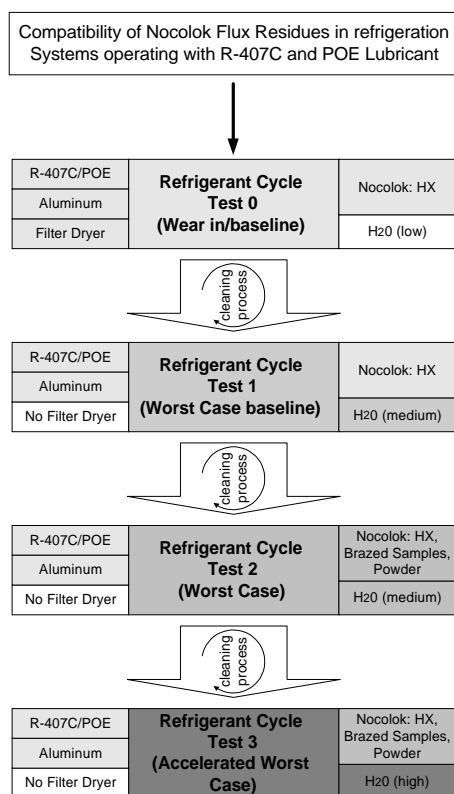

Figure 1: Research Program: Compatibility of Nocolok® Flux in refrigerating systems operating on R 407C and POE lubricant.

The program consists of four tests in which the operating conditions have gradually been debased, up to the point in which a much higher amount of moisture than normally accepted was in the system. Each test took about 500 h, except test 0, which was performed to generate a base line and to exclude any malfunctions of the test rig.

Test Apparatus

The test rig that was used for the stability tests was already described in [1]. For easier understanding, a schematic diagram is given in figure 2.

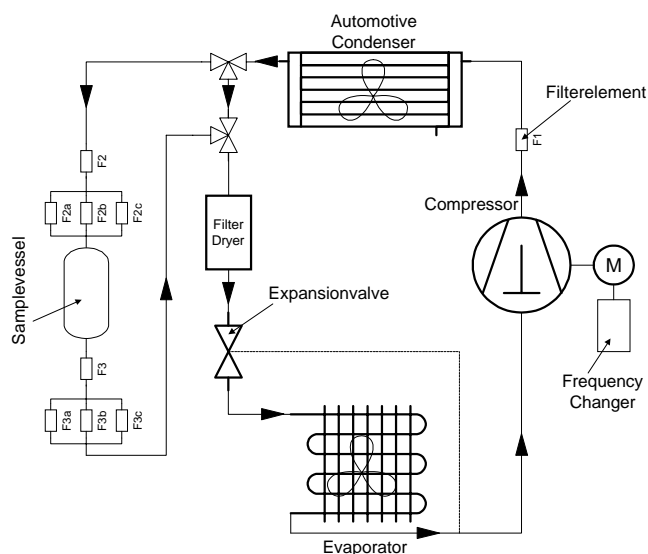

Figure 2: Schematic diagram of the test apparatus

For building the test apparatus, only selected materials were utilised. Apart from sealing material (mostly PTFE and paper sealing of the compressor) the complete test rig is made of stainless steel and aluminium for the evaporator and the condenser. It was essential to choose those components to minimise the amount of influencing parameters in order to be able to detect possible sources of problems.

A test section consisting of filter elements and a sample vessel was located in the liquid line. The filter elements are made of wire mesh and dry powdered stainless steel and are used as an indicator of chemical reactions or corrosion effects. Before and after the sample vessel a combination of a 40 micron filter followed by three 15 micron filters in parallel and in direction of the flow was implemented. Before each test, a new set of filter elements was fitted into the test section to ensure equal conditions for each test. A frequency converter was added to the setup in order to adapt the rotational speed of the compressor to the volumetric capacity of R407C.

Sample Preparation

Angle on Coupon Samples:

For test 2 and 3, the surface of 45 aluminium coupons (see Figure 3) were coated with Nocolok[®] Flux. To simulate joints as produced by continuous furnace processes, aluminium angles were brazed under nitrogen to these coupons.

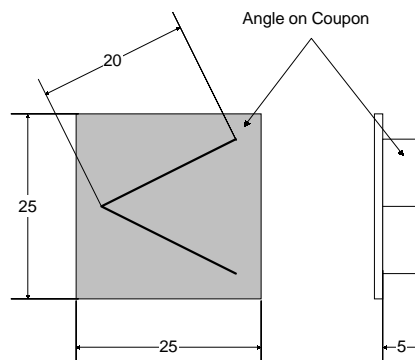

Figure 3: Angle on Coupon Samples

The following dimensions and materials were used for the samples:

Coupon:	Sizes 25 x 25 x 0.4 mm
Basic Material:	AA 3003
Brazing Material:	10 % AA 4343 (7.5 % Si)
Thickness:	0.4 mm
Angle:	Sizes 40 x 5 x 0.5 mm, Angle 45°, Material 99.5 Al
Coating:	5 g / m ²
Brazing:	30°C / min. until 600°C, for 2 min.

40 of the 45 coupons were introduced in the sample vessel on different levels. The remaining five coupons were used as a reference after the tests. The preparation of the angles on coupon are described in detail in [2].

Mechanically detached Residues:

For the stability tests 2 and 3, Nocolok[®] Flux residues as generated by flame brazing processes were mechanically detached and also added into the sample vessel of the test section. The sample that was used to produce these residues was prepared as follows:

Coupon Thickness:	1.5 mm
Aluminium-sheet:	Basic Material AA 3003
Brazing Material (clad):	10 % AA 4343 (7.5 % Si)
Coating:	> 10 g / m ²
Brazing:	until the melting point of the filler metal was reached (577 – 591°C°)

The weight of "Nocolok[®] Flux-powder" given into the vessel was 0,5004 g before test 2 and 0,5005 g before test 3.

The excess flux residue was introduced to create a large surface area in direct contact with the refrigerant / lubricant mixture. Consequently, any potential interactions in the system would be maximised under these conditions.

Test Procedures

The tests were performed for a period of 500 h. The evaporating temperature was held at roughly 0°C and the condensing temperature was set to approximately 55°C. The operating parameters were constantly tracked by a data acquisition. A total of 7 temperatures and 4 pressures were recorded to evaluate the system performance. The pressure drop over the test section was also measured. This is of particular importance, since the loose residues, that were incorporated into the test section, were expected to block the filters to a certain degree.

The incorporated water amount in test 3 was 1,7 g which corresponded to 400 ppm related to the combined weight of refrigerant and oil. The water was injected into the evacuated test rig before the charging of the installation.

Test Cycles – Results***Lubricant analysis of test 2 and 3:***

Both oil-samples of test 2 and 3 showed no significant impurities. Both samples are in good condition and comparable with fresh oil quality. The water contents from the lubricant analysis reflect the means that were taken to increase the humidity in the system.

Table 1: Oil-analysis DEA® RENISO TRITON® SE 55 by FUCHS PETROLUB AG:

	Units	Virgin	Test 2:	Test 3:
Viscosity at 40°C	mm ² /s	52,5	50,5	51,8
Viscosity at 100°C	mm ² /s	8,7	7,8	8,0
NZ	mg KOH/g	0,01	0,06	0,06
H ₂ O	ppm	<50	128	217
ICP-Elements	ppm	Not detectable	Not detectable	Not detectable

Weight analysis of the angle on coupon samples of Test 2 and 3:

Table 2: Weight analysis of angle on coupon samples of Test 2 and Test 3

	total before test [g]:	total after test [g]:	difference [g]:
Test 2:	38,360866	38,3596	-0,0012666
Test 3:	38,252366	38,244466	-0,0079

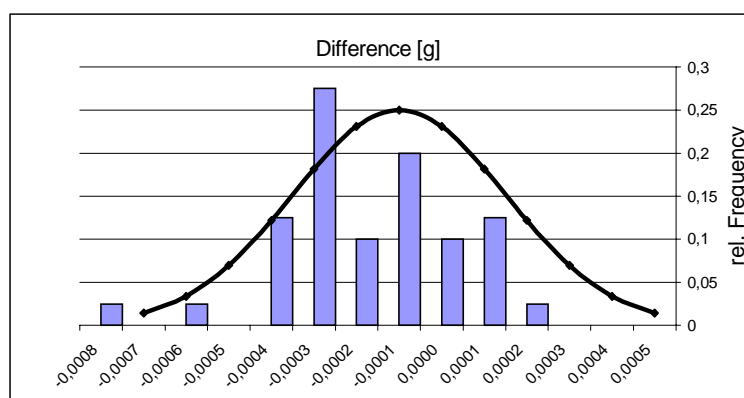
**Figure 4:** Frequency distribution Test 3

The measured weight differences of the coupons are close to the precision tolerance of the scale ($\pm 0,0001\text{g}$). Weight deviations between test 2 and virgin conditions are within the inaccuracy of the scale and therefore insignificant.

A slight weight loss between virgin conditions and test 3 was detected which could have been caused by abrasion effects.

Refrigerant analysis:

GC analysis of the refrigerant was performed after each test. Due to the zeotropic nature of R407C the composition of the three components varied among the analysis. None of the tests however showed any proof of additional substances that would indicate decomposition of the refrigerant.

Optical analysis:

Optical analysis were made on the surfaces of the tube elements, the compressor's valve plate, the coupons and the filter elements. The results were documented with photos. Neither on the surface of the coupons nor on the tubes' surfaces or on the compressor's valve plate any kind of corrosion effects were visible. Figure 5 shows the condition of a stainless wire mesh filter element before and after test 3. The residues which are visible after test 3 consist of loose Nocolok[®] Flux powder which was incorporated into the sample vessel prior to the test.

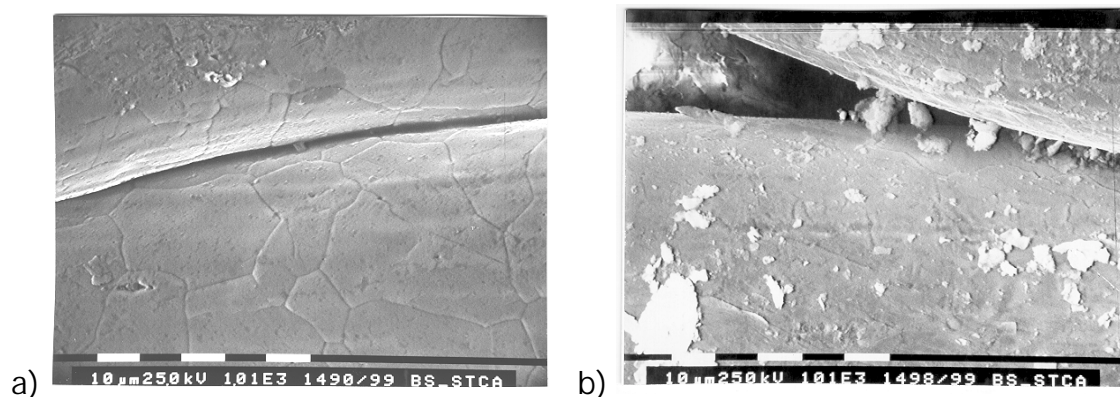

Figure 5: 1000-fold increase shot of a stainless-wire-mesh filter element:

- a) before test 3
- b) after test 3

Discussion of Results

Neither the analysis of the refrigerant and the oil, nor the gravimetric and optical analysis of the filter elements, the "angle on coupons" and the tubes or the compressor gave reason to assume any interactions between Nocolok[®] Flux the refrigerant and the oil. It can be excluded that the presence of flux residues accelerates any corrosive effects.

The amount of flux residues present in the system by far exceeds the amount that would be found in practice. The water content, especially in the last test significantly exceeds practical values. All parameters of the system chemistry remained stable. The analysis of the neutralisation number by the oil's manufacturer showed that the oil is in good condition comparable with fresh oil quality.

Brazed heat exchangers for stationary refrigeration systems

Mechanically expanded finned tube heat exchangers are the most prominent choice for the air-side heat exchange of stationary refrigeration and air-conditioning systems. Copper and aluminium for the tube and fin respectively are the materials of choice. The fins have bear collars which serve to fix the fin on the tube through mechanical or hydraulic expansion of the tube. Two surfaces in contact create an imperfect interface that impedes heat transfer between the two surfaces (figure 6). The impedance is known as the contact resistance.

A simplified description of the heat transfer through a finned tube heat exchanger is shown in figure 7. Five sectors can be assigned to the temperature curve. Sector I describes the heat transfer from the fluid 1 to the inner tube surface, sector II the heat conductance through the tube wall, sector III the heat transfer between outer tube wall and fin collar, sector IV the heat conductance through the fin and sector V the heat transfer from the fin surface to the air.

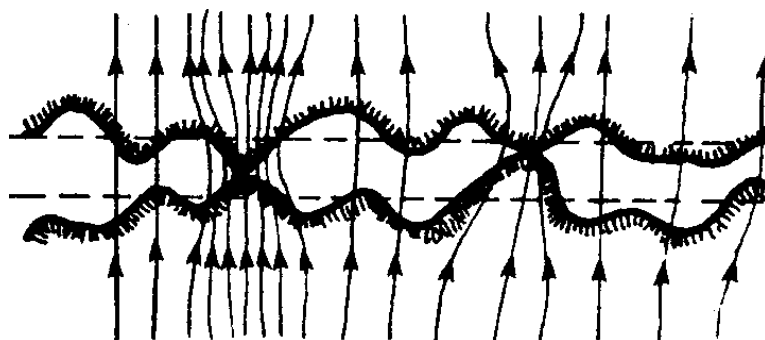

Figure 6: Heat transfer through two surfaces in contact

Section III that describes the contact resistance between tube wall and collar can take up to 12% of total heat resistance. [3].

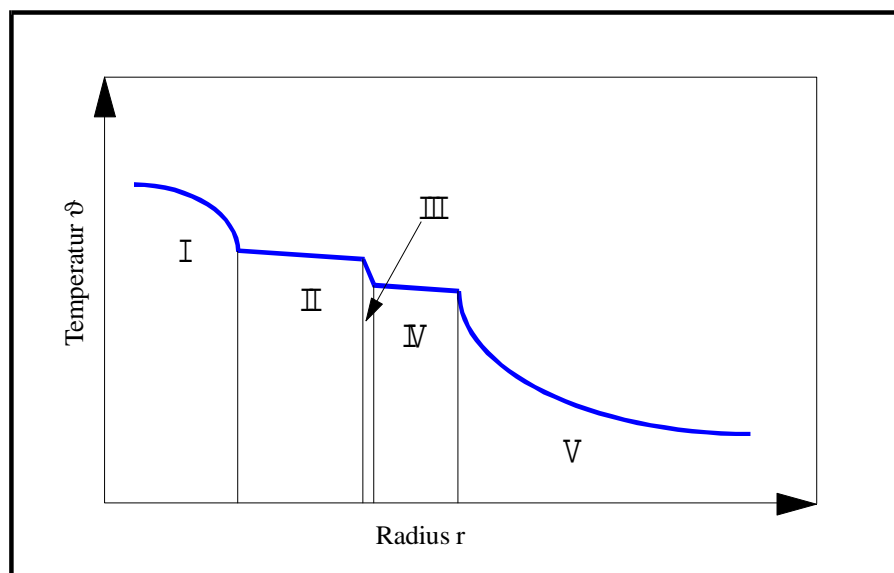

Figure 7: Temperature curve through a finned tube profile

Literature research

Some papers are published on the estimation of the contact resistance between tube and fin-collar.

The first important investigation was done by Dart [4], who connected two tubes with fins and measured the temperature difference between both tubes. The difference served as an index for the quality of heat conductance.

Eckels [5] continued the method of Dart and developed an equation that evaluates the contact resistance as a function of the interface pressure between fin-collar and tube wall and the contact conductance.

Sheffield [6] developed a semi theoretical calculation model which took geometric and material specific data into account.

Critoph [3] created a test rig for measurements of industrial manufactured finned tube heat exchangers in comparison to brazed micro channel heat exchangers. According to the result, the contact resistance accounted for up to 12 % of the total heat resistance on the air side. For brazed heat exchangers contact resistance between fins and tubes is virtually eliminated.

The results from Critoph give practical evidence of increased efficiency, when brazed heat exchangers are used instead of mechanically assembled units.

For automotive applications fully brazed aluminium heat exchangers are the state of the art. In addition to the increased heat transfer behaviour, fully brazed aluminium heat exchangers show a number of other benefits like low material costs, low weight, good resistance against atmospheric influences and of course the easier way of recycling.

For the practical and straight forward comparison of different heat exchanger designs SOLVAY built a two channel test-rig (figure 8) which allows direct comparison of differently designed and produced heat exchangers. First results of the investigations are expected in the second half of the year 2000.

Conclusion

Most materials have an influence on the stability of the couple refrigerant/lubricant. The test apparatus, described above, was created with a limited amount of materials. It can be excluded that the chosen materials have a negative effect on the stability of the couple refrigerant/lubricant. The test approach developed during the stability tests for R 134a/PAG-lubricant, offers the possibility, by successive debasing of the operation conditions, to identify at what level of contamination a safe operation in the long term cannot be guaranteed and to retrace whence the problem is caused.

The following conclusion was obtained:

The presence of brazing flux residues has no negative influence on the apparent running conditions and the stability of a refrigeration system operating on R 407C and POE lubricant, even under worst conditions such as the absence of a filter dryer, and with an artificially high moisture content.

Even under worst case conditions, there is no evidence that flux residue accelerates, contributes to or catalyses the decomposition of the lubricant, refrigerant components or damage any other component of this system.

Fully brazed aluminium heat exchangers are already established in automotive air-conditioning systems. Theoretical investigations promise a heat transfer benefit of up to 12 %, when fully brazed heat exchangers are used instead of conventionally manufactured ones. Other benefits for stationary refrigeration and air-conditioning systems which follow from the use of aluminium heat exchanger are lower material costs and weight, better resistance against environmental influences, and minimised recycling problems.

Outlook

For the practical evaluation of the heat transfer benefit, SOLVAY will perform a series of tests. Therefore a test rig was built which allows to compare heat exchangers of different designs under same conditions (figure 8). First results are expected in the second half of the year 2000.

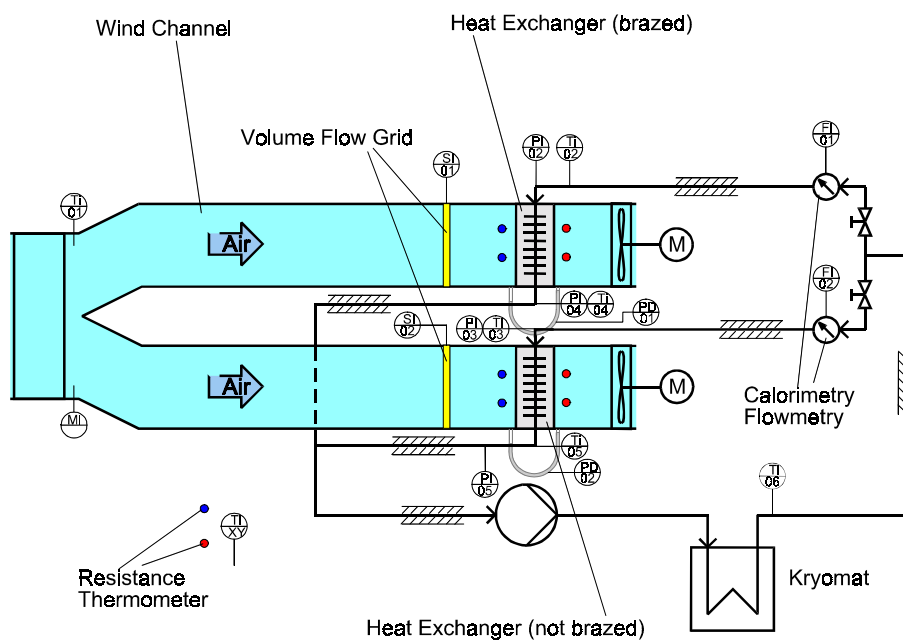

Figure 8: Test rig for the direct comparison of different heat exchangers

ACKNOWLEDGEMENTS:

The authors would like to thank Martin Schwiegel, for his work on his diploma thesis and for performing the R407C / POE stability tests.

Furthermore we would like to acknowledge FUCHS / DEA MINERALOELWERKE for their support with the analysis of the lubricant.

Reference

- [1] Meurer, C.; Lauzon, D.; Koenig H.: Influence of Residues from Aluminum Brazing Processes on Refrigerant Systems Involving R134a and PAG Lubricants, Purdue Refrigeration and Compressor Engineering Conference '98
- [2] Meurer, C.; Lauzon, D. C.; Koenig, H.: Stability of R-134a in the Presence of Nocolok[®] Flux Residues; SAE 980052; SAE International Congress and Exposition, Detroit, 1998
- [3] Critoph, R.E., Holland, M. K.; Turner, L.: Contact Resistance in air-cooled Plate Fin-Tube air-conditioning Condensers, Int. J. Refrig., Vol. 19, 1996, No. 6, Page 400-406
- [4] Dart, D. M.: Effect on Fin Bond on Heat Transfer, ASHRAE Journal, May 1959, Page 67-71
- [5] Eckels, P. W.: Contact Conductance of mechanically expanded Plate Finned Tube Heat Exchangers, ASME Paper No. 77-HAT-24, 1977
- [6] Sheffield, J.W.; Sauer, Jr., H.J.; Wood, R.A.: Thermal Contact Conductance of Finned Tubes: A generalized Correlation